

KempCool

10

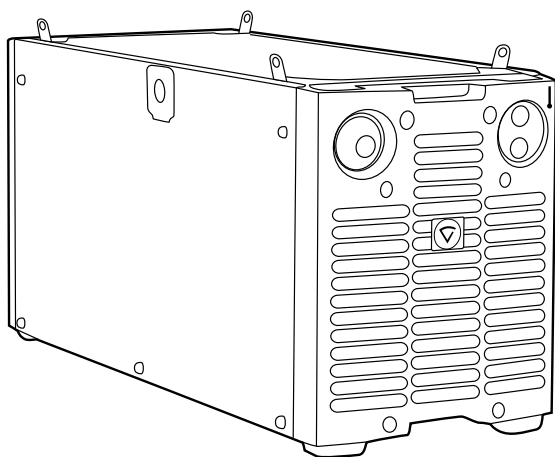

Operating manual *EN*

Bruksanvisning *DA*

Gebrauchsanweisung *DE*

Manual de instrucciones *ES*

Käyttöohje *FI*

Manuel d'utilisation *FR*

Gebruiksaanwijzing *NL*

Bruksanvisning *NO*

Instrukcja obsługi *PL*

Manual de utilização *PT*

Инструкции по эксплуатации *RU*

Bruksanvisning *SV*

OPERATING MANUAL

English

CONTENTS

1.	Preface.....	3
1.1	General.....	3
2.	Installation	4
2.1	Removal from packaging	4
2.2	Locating the machine.....	4
2.3	Serial number.....	4
2.4	Installation and main parts.....	4
	2.4.1 Assembling the equipment	4
	2.4.2 Main parts of cooling unit	5
2.5	Preparing for operation	5
2.6	Cooler operation	6
2.7	Overheat signal lamp.....	6
2.8	Storage.....	6
3.	Maintenance	6
3.1	Daily maintenance.....	7
3.2	Regular maintenance.....	7
	3.2.1 Every sixth months.....	7
	3.2.2 Maintenance by agreement.....	7
4.	Disposal	7
5.	Trouble shooting	8
6.	Technical data	8

1. PREFACE

1.1 General

Congratulations on your choice of the KempCool 10 cooling unit. Reliable and durable, Kemppi products are affordable to maintain, and they increase your work productivity.

This user manual contains important information on the use, maintenance and safety of your Kemppi product. The technical specifications of the device can be found at the end of the manual. Please read the manual carefully before using the equipment for the first time. For your safety and that of your working environment, pay particular attention to the safety instructions in the manual.

For more information on Kemppi products, contact Kemppi Oy, consult an authorised Kemppi dealer, or visit the Kemppi Web site at www.kemppi.com. The specifications presented in this manual are subject to change without prior notice.

Important notes

Items in the manual that require particular attention in order to minimise damage and personal harm are indicated with the **'NOTE!'** notation. Read these sections carefully and follow their instructions.

2. INSTALLATION

2.1 Removal from packaging

The equipment is packed in durable packages specially designed for them. Check the equipment before taking it into use, to make sure that the equipment or a part of it have not got damaged during the transportation. Also check that the delivery corresponds your order and that you have received all the necessary instructions for installing and operating the equipment. The packaging material can be recycled.

2.2 Locating the machine

Place the machine on a horizontal, stable and clean ground. Protect the machine from heavy rain and burning sunshine. Check that there is enough space for cooling air circulation in front of and behind the machine.

EN

2.3 Serial number

The serial number of the machine is marked on the machine CE-marking. Identificating the serial number is the only proper means of maintaining and identifying parts for a specific product. It is important to make correct reference to the serial number of the product when making repairs or ordering spare parts.

2.4 Installation and main parts

2.4.1 Assembling the equipment

The equipment is assembled in the following order:

1. Transport unit PM500 6185291
2. Cooling unit KempCool 10 6208100

Assembly the transport unit according to the instructions in the package. Fasten the cooling unit to the transport unit by using the screws and bolts delivered with the equipment.

2.4.2 Main parts of cooling unit

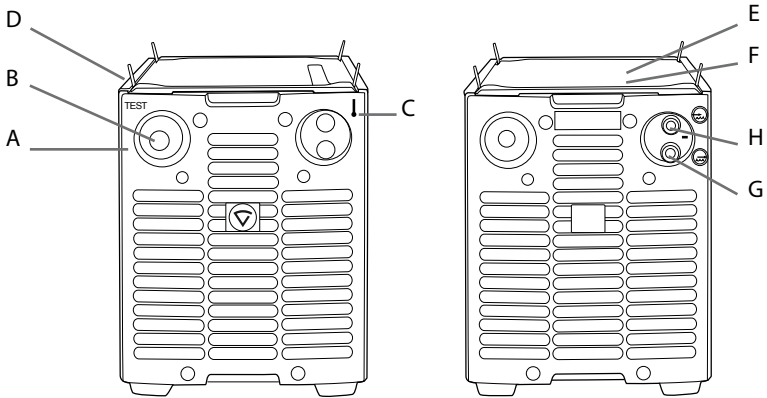

Front machine

- A. Housing
- B. Test switch
- C. Overheat control lamp
- D. Filling hole

Back side

- E. Mains voltage connection cable
- F. Control cable
- G. Cooling water output hose
- H. Cooling water input hose

2.5 Preparing for operation

NOTE! Cooling liquid is injurious! Avoid also contact with skin or eyes. In case of injury, seek for medical advice.

See also 2.4.2. Main parts of cooling unit.

1. Connect the mains voltage and control connectors of the cooler unit to the corresponding connectors on the base of the power supply. The connection can be established through the base of the power supply when the devices are separated or through the right side of the KempCool 10 cooler by removing the right side plate.
2. Attach the power supply on the KempCool 10 cooler.

3. Connect the cooling water hoses with the wire feed unit, follow colour markings.
4. Fill the reservoir with a 40 – 20 % mixture of etanol and water, or with any other suitable antifreeze agent. The capacity of the reservoir is 3 litres.
5. Switch on the power supply.
6. Press and hold down the test switch until the torch hoses are filled with liquid.
7. Device is ready to weld.

2.6 Cooler operation

See also 2.4.2. Main parts of cooling unit

KempCool 10 operation is controlled by the microprocessor of the power supply. The cooler pump starts to operate when the welding begins. After the welding has stopped, the pump will operate 1 to 5 minutes longer depending on the welding time. During this time the liquid will cool down to the surrounding temperature. If the pump is stopped, the need for maintenance of the cooler will be reduced.

Check the tank liquid level regularly and fill in liquid, if necessary.

If the the container has ran out of liquid the welding is stopped and error code, Err 5, appears on the KempArc panel.

2.7 Overheat signal lamp

The overheat signal lamp is lighting when temperature control of the machine has detected cooling water overheat. The ventilator cools down the machine and when the lamp goes out welding can be started again.

2.8 Storage

The machine must be stored in a clean and dry room. Protect the machine from rain and keep it away from direct sunshine in places where temperature exceeds +25 °C. Check that there is free space in front of and behind the machine for air circulation.

3. MAINTENANCE

NOTE! Watch out for mains voltage when handling electric cables!

In planning product maintenance machine utilization degree and circumstances should be considered. Careful use and preventive maintenance help to avoid unnecessary production disturbances and breaks.

3.1 Daily maintenance

The following maintenance operations should be carried out daily:

- Check water level and input flow, add liquid if needed.
- Check cables and connections. Tighten, if necessary and replace defect parts

3.2 Regular maintenance

Make sure that the machine receives regular and appropriate maintenance. Authorised Kemppi service agents perform regular maintenance by agreement. For more information on regular maintenance, contact a Kemppi representative.

3.2.1 Every sixth months

The following maintenance operations should be carried out at least every sixth months:

- Clean off dust and dirt. Change the cooling liquid and wash up the pipes and water reservoir with pure water.
- Check seals, cables and connections. Tighten, if necessary and replace defect parts.

3.2.2 Maintenance by agreement

Authorised Kemppi service agents perform regular maintenance by agreement. During the maintenance the machine is cleaned and checked for faults. The functionality of all parts is tested and the possible faults are repaired.

4. DISPOSAL



Do not dispose of electrical equipment with normal waste!

In observance of European Directive 2002/96/EC on waste electrical and electronic equipment, and its implementation in accordance with national law, electrical equipment that has reached the end of its life must be collected separately and taken to an appropriate environmentally responsible recycling facility.

The owner of the equipment is obliged to deliver a decommissioned unit to a regional collection centre, per the instructions of local authorities or a Kemppi representative. By applying this European Directive you will improve the environment and human health.

5. TROUBLE SHOOTING

See also 2.7. Overheat signal lamp.

Overheat signal lamp is lit.

The unit is overheated.

- Check water circulation.
- Check that there is enough free space behind the machine for cooling air circulation.

Error code Err 5/Err 27 on the panel

- Check the liquid hoses for damages.
- Remove any hose blockages.
- Check water circulation, add liquid if needed.

For further information and assistance, contact your nearest Kemppe service workshop.

EN

6. TECHNICAL DATA

Cooling unit KempCool 10		
Operating voltage		400V -15% ... +20%
Connection capacity	100 % ED	250 W
Cooling power		1 kW
Start pressure, max.		0.4 MPa
Cooling liquid		20 % – 40 % etanol/water
Tank volume		3 l
External dimensions	LxWxH	570x230x280 mm
Weight		11 kg
Operating temperature range		-20 ... +40 °C
Storage temperature range		-40 ... +60 °C
EMC class		A
Degree of protection		IP23S

KEMPPI OY

Kempinkatu 1
PL 13
FI-15801 LAHTI
FINLAND
Tel +358 3 899 11
Telefax +358 3 899 428
export@kemppi.com
www.kemppi.com

Kotimaan myynti:

Tel +358 3 899 11
Telefax +358 3 734 8398
myynti.fi@kemppi.com

KEMPPI SVERIGE AB

Box 717
S-194 27 UPPLANDS VÄSBY
SVERIGE
Tel +46 8 590 783 00
Telefax +46 8 590 823 94
sales.se@kemppi.com

KEMPPI NORGE A/S

Postboks 2151, Postterminalen
N-3103 TØNSBERG
NORGE
Tel +47 33 346000
Telefax +47 33 346010
sales.no@kemppi.com

KEMPPI DANMARK A/S

Literbuen 11
DK-2740 SKOVLENDE
DANMARK
Tel +45 4494 1677
Telefax +45 4494 1536
sales.dk@kemppi.com

KEMPPI BENELUX B.V.

Postbus 5603
NL-4801 EA BREDA
NEDERLAND
Tel +31 765717750
Telefax +31 765716345
sales.nl@kemppi.com

KEMPPI (UK) LTD

Martti Kemppi Building
Fraser Road
Priory Business Park
BEDFORD, MK44 3WH
UNITED KINGDOM

Tel +44 (0)845 6444201
Telefax +44 (0)845 6444202
sales.uk@kemppi.com

KEMPPI FRANCE S.A.S.

65 Avenue de la Couronne des Prés
78681 EPONE CEDEX
FRANCE
Tel +33 1 30 90 04 40
Telefax +33 1 30 90 04 45
sales.fr@kemppi.com

KEMPPI GMBH

Perchstetten 10
D-35428 Langgöns
DEUTSCHLAND
Tel +49 6 403 7792 0
Telefax +49 6 403 779 79 74
sales.de@kemppi.com

KEMPPI SPÓŁKA Z O.O.

Ul. Borzymowska 32
03-565 WARSZAWA
POLAND
Tel +48 22 7816162
Telefax +48 22 7816505
info.pl@kemppi.com

KEMPPI AUSTRALIA PTY LTD

13 Cullen Place
P.O. Box 5256, Greystanes NSW 2145
SMITHFIELD NSW 2164
AUSTRALIA
Tel. +61 2 9605 9500
Telefax +61 2 9605 5999
info.au@kemppi.com

ООО КЕМППИ

Polkovaya str. 1, Building 6
127018 MOSCOW
RUSSIA
Tel +7 495 739 4304
Telefax +7 495 739 4305
info.ru@kemppi.com

ООО КЕМППИ

ул. Полковая 1, строение 6
127018 Москва
Tel +7 495 739 4304
Telefax +7 495 739 4305
info.ru@kemppi.com

KEMPPI, TRADING (BEIJING) COMPANY LTD

Room 420, 3 Zone, Building B,
No.12 Hongda North Street,
Beijing Economic Development Zone,
100176 BEIJING
CHINA
Tel +86-10-6787 6064
+86-10-6787 1282
Telefax +86-10-6787 5259
sales.cn@kemppi.com

肯倍贸易 (北京) 有限公司
中国北京经济技术开发区宏达
北路12号
创新大厦B座三区420室 (100176)
电话: +86-10-6787 6064
+86-10-6787 1282
传真: +86-10-6787 5259
sales.cn@kemppi.com

KEMPPI INDIA PVT LTD

LAKSHMI TOWERS
New No. 2/770,
First Main Road,
Kazura Garden,
Neelankarai,
CHENNAI - 600 041
TAMIL NADU
Tel +91-44-4567 1200
Telefax +91-44-4567 1234
sales.india@kemppi.com

KEMPPI WELDING SOLUTIONS SDN BHD

No 12A, Jalan TP5A,
Taman Perindustrian UEP,
47600 Subang Jaya,
SELANGOR, MALAYSIA
Tel +60 3 80207035
Telefax +60 3 80207835
sales.malaysia@kemppi.com